

New Material for Illuminated Panels
Microcellular Reflective Sheet

MCPET

- Contributes bright internally lit sign panels with improved sign surfaces
 - Cuts energy cost of facade signs by 50%
 - Reduces illumination blurs (striped patterns of lamps)
- Reduces illumination blurs and color variations in LED planar light sources (backlights and sign panels)



● Walkway to Tokyo Opera City
(Hatsudai Station on the Keio New Line)



● Sign in Kyoto Station (Tokaido Shinkansen)



Superior Illumination of Microcellular PET Sheet

MCPET Realizes Br

1

Reflectance is increased 99%, of which 96% is diffused reflection. Reflection is balanced between blue and red light.

As the diffused reflectance of mirrored or metallic reflection panels is less than 10%, such panels are only able to reflect the light source in a specified direction. Moreover, metallic reflection panels absorb red light, changing the color of the reflected light to a bluer tint than the original light source. Since the reflectance ratios low to begin with, the reflected light becomes dark and bluish. As can be seen in the figure below, MC-PET reflects blue light with wavelengths of 400 nm and red light with wavelengths of 700 nm nearly equally, allowing the production of very bright sign surfaces.

Superior reflectance results in bright sign surfaces.

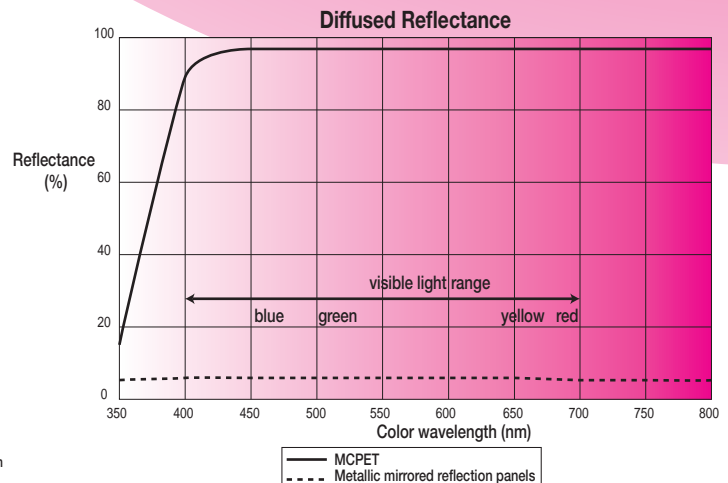
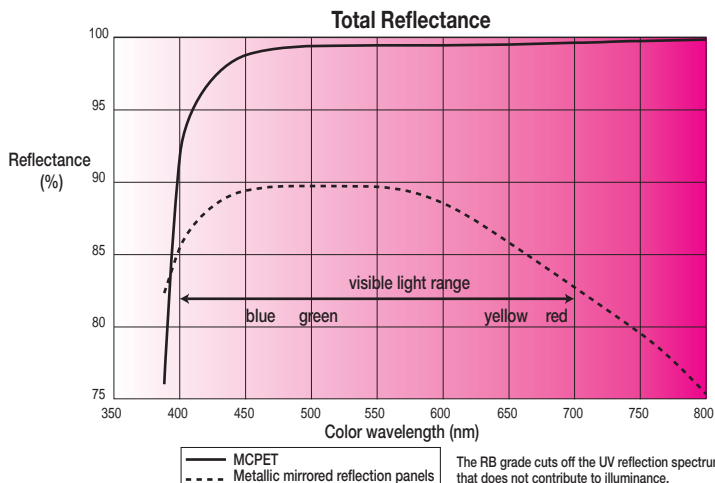

2

Energy costs can be reduced by 50% for facade signs and 30% for conventional signs.

- By placing MC-PET reflection panels not only behind but also above, below and beside fluorescent lights, necessary lighting can be reduced from two rows to one row of 40 watt lights for a facade sign with a 1100 mm width. See the figure below left for an example of results.
- For a conventional sign using lighting of seven fluorescent lights per 2m² (1.5m x 1.2m), the use of MC-PET reflection panels reduces the necessary lighting to five lights per 2m². The cost savings reflect the reduction of one fluorescent light bulb per square meter of lighting. See the figure below right.

High reflectance reduces necessary lighting to save energy.

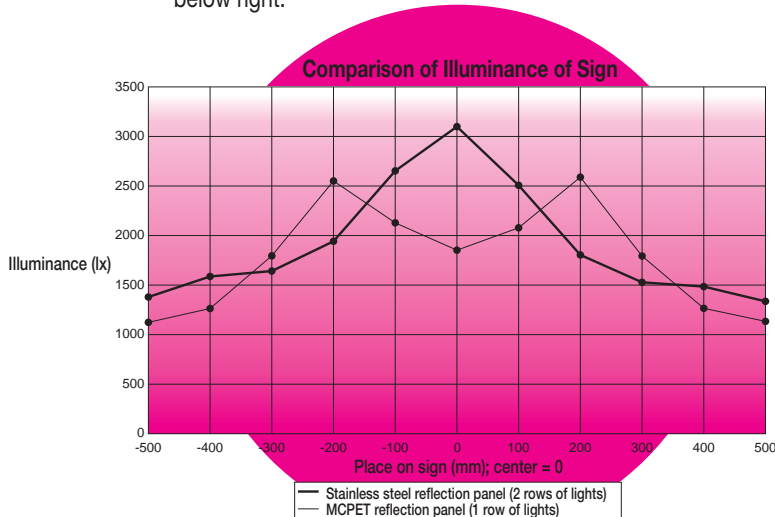

1. Fluorescent Lights Reduced 30% (per 2m², 1.5m x 1.2m)

	Fluorescent wattage	Lights	Row pitch (nm)
Current methods	40 watts	7	200 pitch
MC-PET	40 watts	5	300 pitch

2. For lights on 20 hours per day, annual energy costs can be cut 7,300 yen per square meter.

Energy savings (per 2m²) 2 x 40 - watt fluorescent lights

Energy savings per day
40 watts x 2 lights x 20 hours per day = 1,600 watt-hours per day

Energy savings per year
1.6 x 25 yen x 365 days = 14,600 14,600 yen per 2m²
14,600 / 2m² = 7,300 7,300 yen

Right, Vivid Displays

3 Illumination blurs (striped patterns of lamps) are reduced. Please consult us for blurs related to especially thin signs (under 40 mm).

In general, when the distance between the lamps and the sign surface is short, the areas immediately above the lamps are overly bright and the areas between lamps are dark, resulting in illumination blurs on the sign surface. Simply by using MCPET reflection panels, higher illuminance between lights results in a more balanced lighting effect and a reduction in blurs and striping. For especially thin signs where reducing the blurring effect is difficult, we have special methods to solve the problem. Please consult us for details.

Stripe patterns caused by internal lights are sharply reduced.

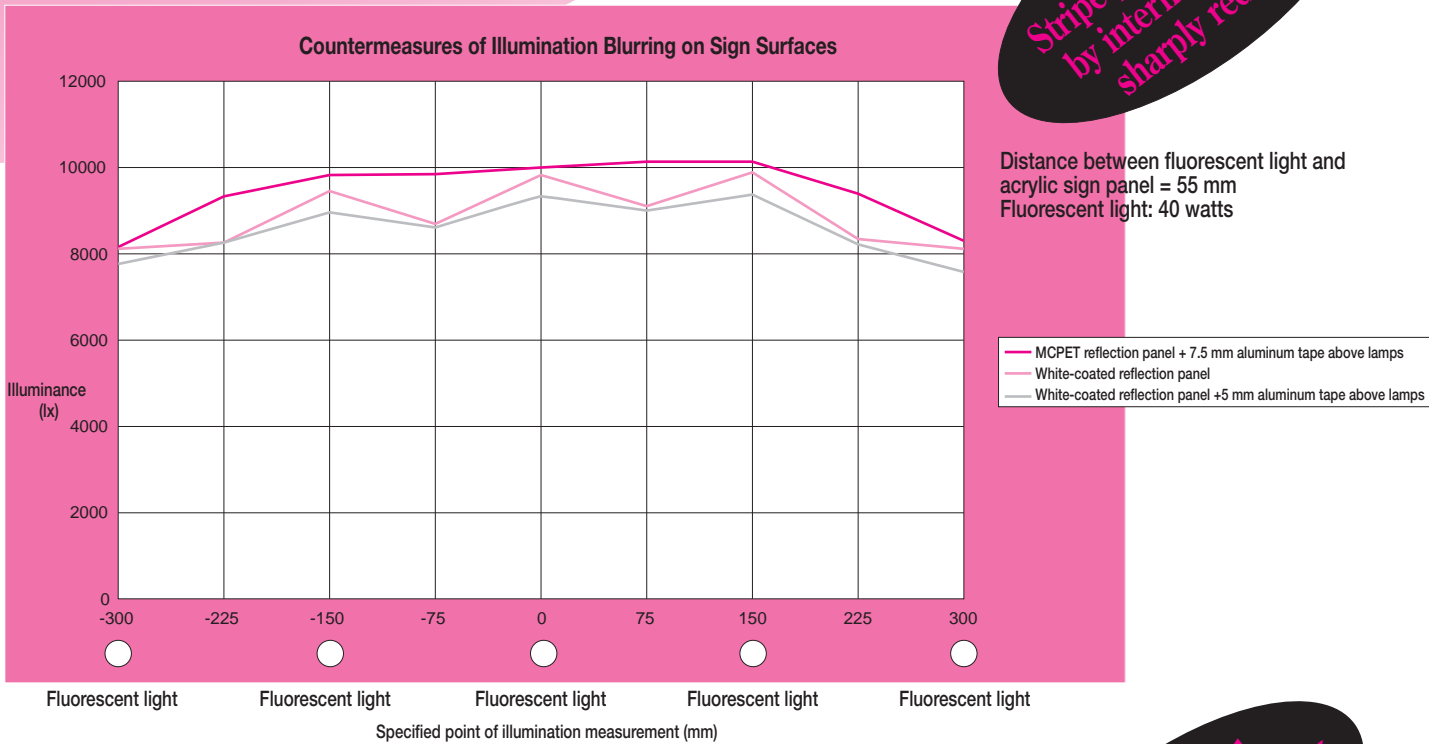

4 Installation is easy with a cutter knife. MCPET panels can be attached behind fluorescent lamps with special two-sided adhesive tape.

We recommend the following two-sided tape.
Manufacturer: Sumitomo 3M Ltd. Product name: VHB™ Double Coated Foam Tape

Processing and installation is really easy.

Tape	Product No.	Thickness	Color	Basic Material		Adhesive	Liner	Temperature Resistance (Note) Exterior
		Tape		Material	Grade	Material		
General use	Y-4950	1.14	White	Acrylic foam	Regular	Acrylic	Paper	-20 to 150 °C

5 Maintenance

Although MCPET is treated with an anti-static process, we recommend cleaning once per year to maintain long-term function.

6

Can be used with various types of products

Illuminated box and luminous ceiling

Conventional structure

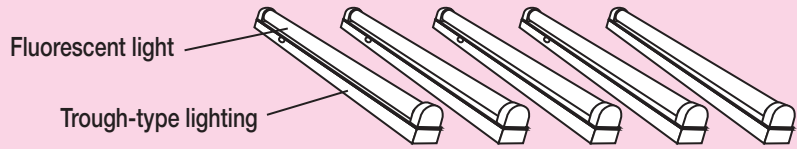

Increasing brightness by 60%
Uneven light output is eliminated

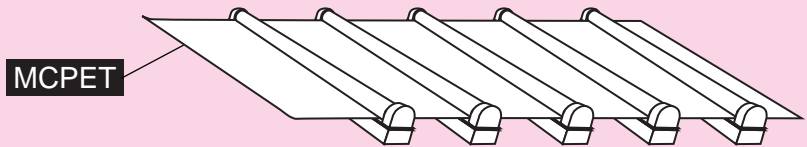

Saving energy by 40%
Same level of illuminance is maintained

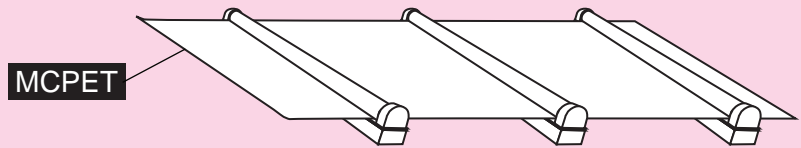

*Installed upside down for luminous ceiling.

Ceiling light

Using MCPET

Two fluorescent lights can provide the same brightness as three or more conventional fluorescent lights.

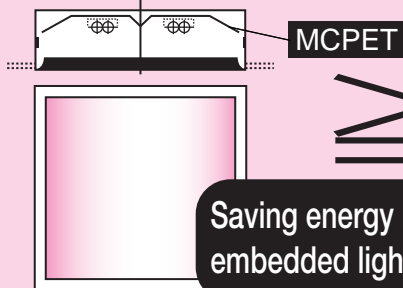

Conventional type

Steel panel with white coating is used for the reflector. Conventional products

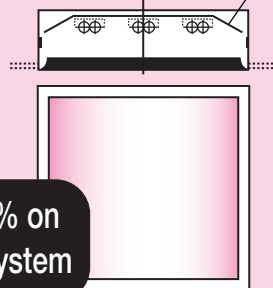

Saving energy by 30% on embedded lighting system

Furthermore, using an energy-saving fluorescent light can save energy by 70% in total.

Showcase

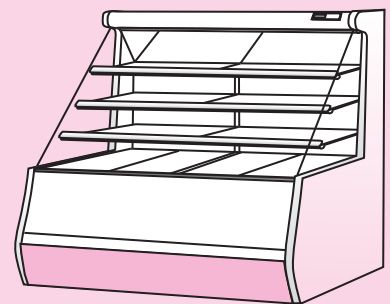

MCPET

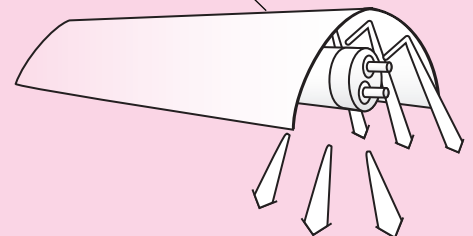

Increasing illuminance by 30%

Increasing illuminance of a showcase

Double-sided signboard

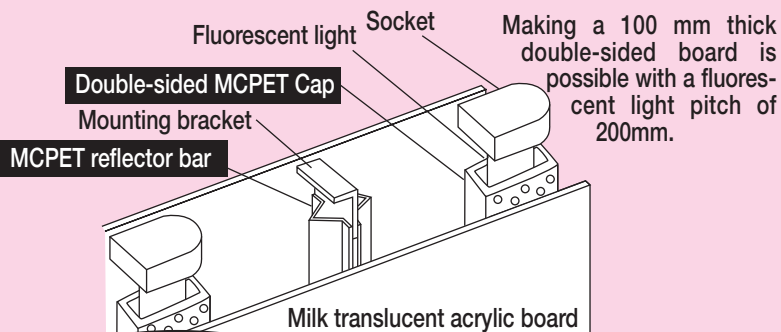

Structure of a thin double-sided light source

Facade Signboard of a Convenience Store

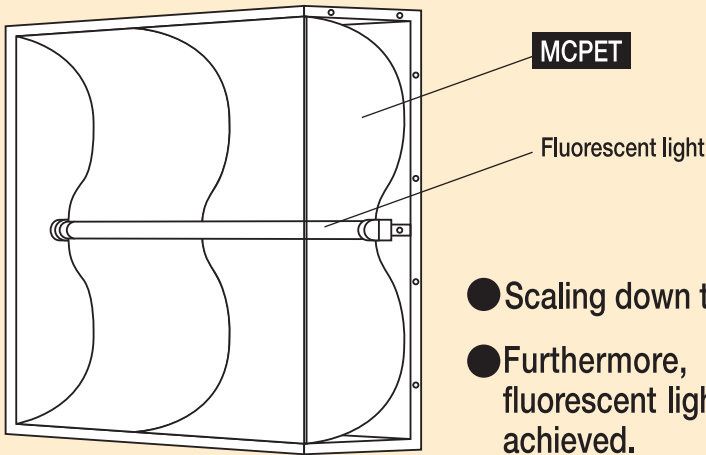

50% to 70% reduction of the energy needed for a conventional facade signboard.

- Scaling down to a one-light system saves 50% energy.
- Furthermore, when used with an energy-saving fluorescent light, a total energy saving of 70% can be achieved.

Thin Signboard

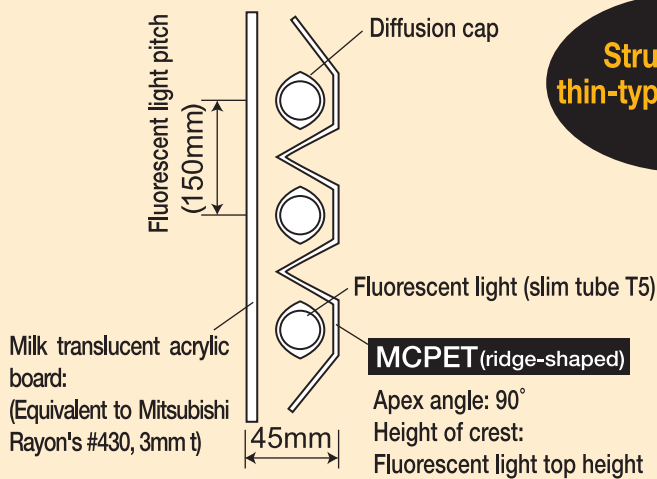

Structure of thin-type signboard

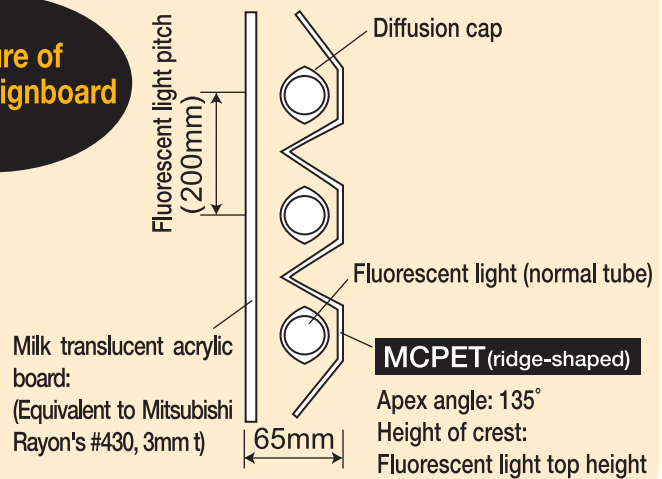

LED planar light source (backlight and signboard)

- Reduces uneven light output.
- Reduces fluctuations in light output

Structure of LED planar light source

- Thin structure is possible.
- The number of LEDs can be reduced if the board is constant in thickness.

Note: Use LEDs with a wide angle of visibility.

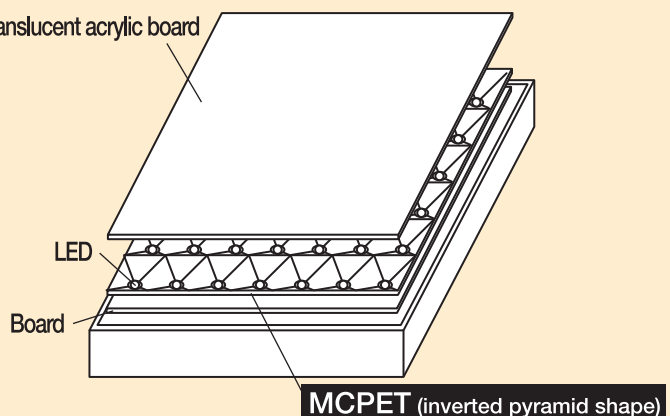
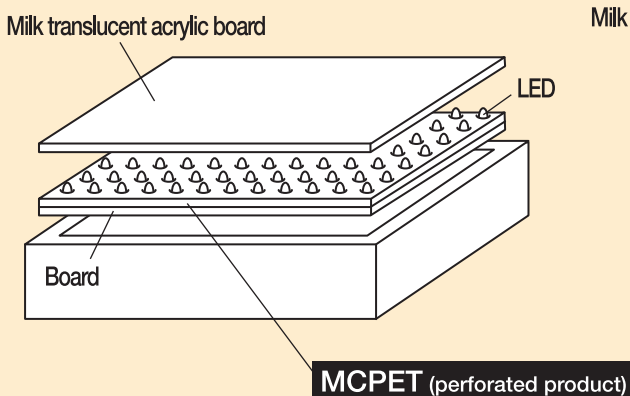

MCPET Sheet Properties

Grade: Standard (RB) Thickness: 1mm

	Item	Direction	Unit	Value	Test method	
	Density	—	kg/m ³	325	JIS K 6767	
	Ave. foam size	—	μm	10 or less	ASTM-D3576-77 compliant	
Optical properties	Total reflectance	—	%	99	Relative to barium sulfate at 550 nm wavelength	
	Diffused reflectance	—	%	96		
Mechanical properties	Tensile strength	MD	MPa	13.5	JIS K 6767	
		TD		13.5		
	Elongation	MD	%	85	JIS K 6767	
		TD		105		
	Tear strength	MD	N/cm	750	JIS K 6767	
		TD		750		
	Flexural strength	MD	MPa	13.5	JIS K 7171	
		TD		13.0		
Flexural modulus	MD	MPa	850	JIS K 7171		
	TD		800			
Electrical properties	Surface specific resistivity	—	Ω	3×10 ¹¹	JIS K 6911	
Thermal properties	Ave. linear expansion	MD	°C ⁻¹	5.0×10 ⁻⁵	JIS K 7197 (20~100°C)	
		TD		5.5×10 ⁻⁵		
	Thermal deformation	100°C	MD	%	-1.1	JIS K 6767 compliant
			TD		-0.8	
		200°C	MD		-5.5	
			TD		-4.5	
Heat deformation temperature (100g)	—	°C	177	JIS K 7196 compliant		
Thermal conductivity (60°C)	—	W/mK	0.06	Heat flow meter		

Certified by UL94-HBF

Product Specifications

Grade	Thickness (mm)	Width (mm)	Length (m)	Packing
RB (Standard)	1.0	600	20	Rolled sheet (box)
RB (Standard)	1.0	600	1.5	Cut sheet (cardboard box)
RB (Standard)	1.0	600	1.2	
RB (Standard)	1.0	600	1.0	

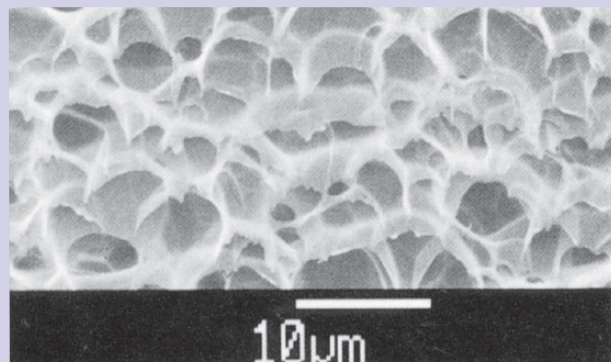

- All data is based on standard grade
- Reflectance is relative to barium sulfate white panels
- Data is based on our best estimates and is not guaranteed
- Information in this catalogue is subject to change without notice
- Product and company names included in this catalogue are registered trademarks of the respective companies

■ For further information contact:

FURUKAWA ELECTRIC

 **FURUKAWA ELECTRIC CO., LTD.**

Foamed Products Division <http://www.furukawa.co.jp/foam/>

2-3, Marunouchi 2-chome, Chiyoda-ku, Tokyo, Japan 100-8322 Tel.+81-3-3286-3458 Fax.+81-3-3286-3472

The products and their appearances, as described in this brochure, are subject to change for improvement without prior notice.

Export Control Regulations

The products and/or technical information presented in this publication may be subject to the application of the Foreign Exchange and Foreign Trade Act and other related laws and regulations in Japan.

In addition, the Export Administration Regulations (EAR) of the United States may be applicable.

In cases where exporting or reexporting the products and/or technical information presented in this publication, customers are requested to follow the necessary procedures at their own responsibility and cost.

Please contact the Ministry of Economy, Trade and Industry of Japan or the Department of Commerce of the United States for details about procedures.